

Fact Sheet

UniSort Film EVO 5.0[®]

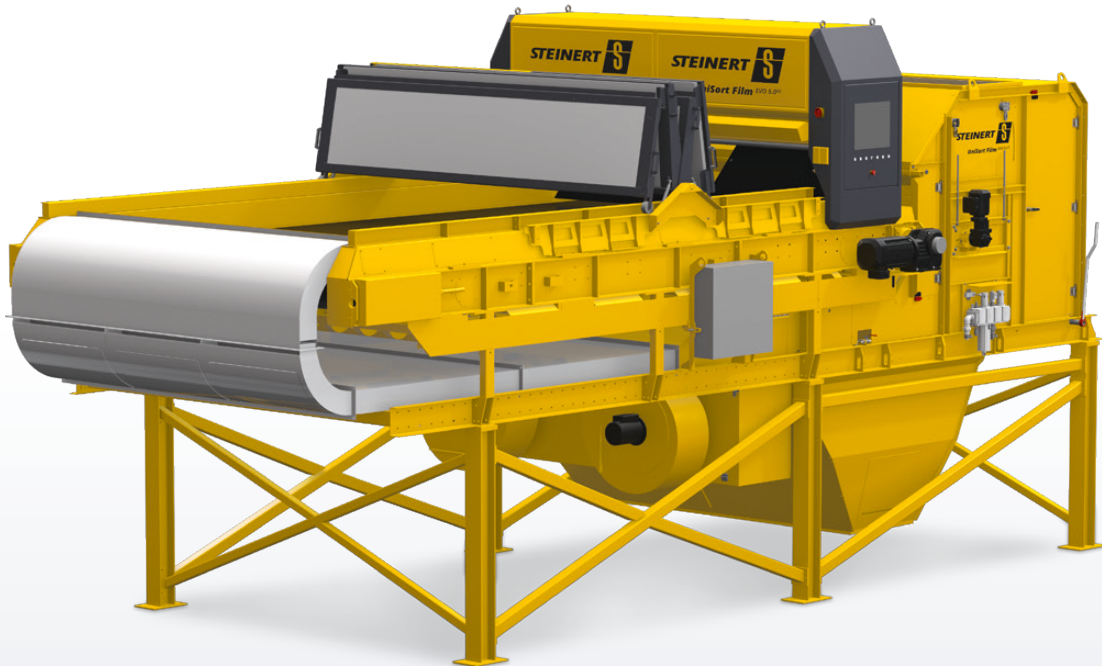

+ WASTE SORTING

- + Detects and sorts 2D and light fractions such as
 - Plastic films
 - Paper, cardboard and fibre mixtures
- + Detects and sorts all common plastics and materials in applications such as
 - Light packaging sorting
 - Household waste processing
 - Commercial and industrial waste processing
 - Substitute fuel production
 - Plastics sorting
 - Foil processing
 - Paper and cardboard sorting
- + Identifies and sorts plastics and materials by type, e.g. PE, PP, PS, PET, PVC, beverage cartons, paper, cardboard, paperboard and textiles

THE RESOURCE
SEARCH ENGINE

CURIOSUS?
Learn more.



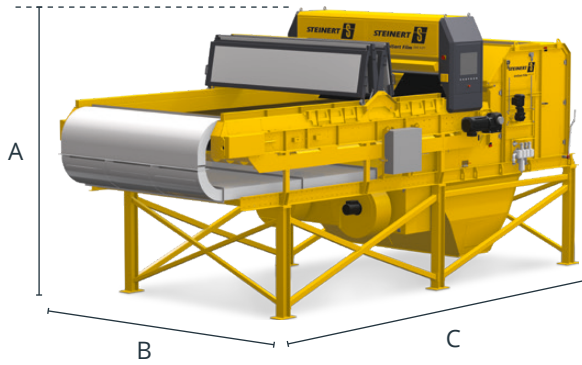

+ TECHNOLOGY

UniSort Film EVO 5.0®

Based on the latest near infrared (NIR) camera technology – hyperspectral imaging (HSI) technology – the advantages lie in the combination of highest local and spectral resolution. The sorting system is also available in combination with a high-resolution colour camera to map further optically detectable characteristic properties.

The Active Object Control controls the way in which the material behaves on the conveyor belt and in combination with intelligent sensor-based technology thereby guarantees a high capacity and sorting reliability at up to 4.5 m/s belt speed.

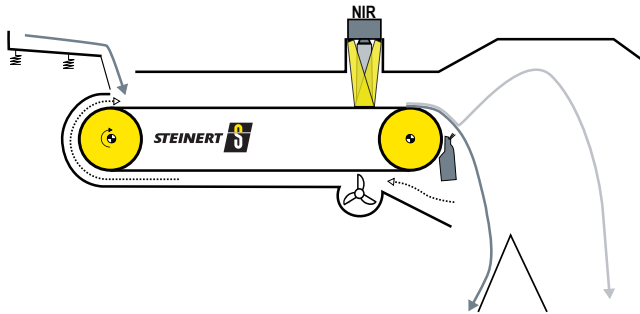

UniSort Film EVO 5.0®		P1000R Film	P1400R Film	P2000R Film	P2800R Film
General					
Working width (mm)		1,000	1,400	2,000	2,800
Dimensions approx. (mm)	A	3,565	3,565	3,565	3,565
	B	1,895	2,300	2,790	3,730
	C	7,800	7,800	7,800	7,800
Weight incl. nozzle bar (kg)		2,450	3,250	3,900	5,700
Environmental specifications					
Permitted ambient temp. depending on version (°C)		-5 to +45			
Installation site		Under roof/indoor			
Conformities					
Given conformities		EN (UL-CSA)			
Electrical specifications					
Machine power consumption (kVA)		7.5	10	12	13
Machine protection class		IP 54 (not certified)			
Pneumatic specifications					
Compressed air quality		ISO 8573-1: class 3.4.4			
Operating pressure (bar)		5–7			
Pneumatic connection (inch)		1			
Options + variants					
Example accessories		Feeder, disk spreader, safety switches			

Technical alterations reserved. For more details see the operating instruction of the sorting system.